

DUPLEX PACKING FILLER AF-50K II

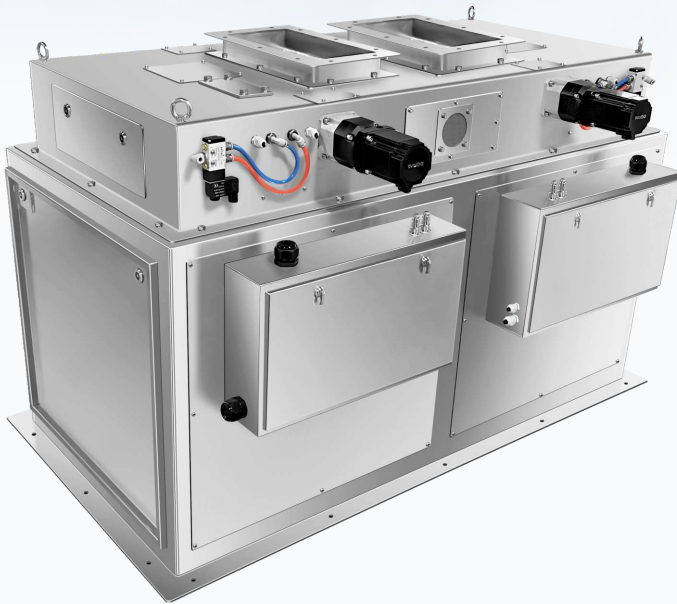

10-50 kg

Weighing range



Stable
Performance



Easy
Installation

± 20g

Accuracy



Servo Motor
Control



Weighing
Accurate

1500+ Pcs/h

Speed

Features:

- **Granular material:** design for big bag packing machine for plastic particles, rice, sugar and other granular material;
- **Easy dismounting:** module design of measuring hopper for easy cleaning;
- **Parameter setting:** self-adjust function with target value set only;
- **Stable performance:** servo motor controls feeding process;
- **Weighing accurate:** weighing range is 10-50kg. Speed can reach 1500 pcs/h and accuracy is ±20g.

Optional:



10-inch touch screen

User-friendly interface design,
vivid display, easy to operate.

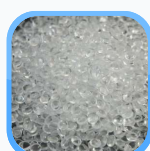

Specification

Model	PaxGo AF-50KII
Weighing range	10~50Kg
Division	1g
Accuracy *	±20 g
Speed *	≥1500 pcs/h
Volume	86L×2
Feeding method	Feeding control by servo, pneumatic discharging
Material	SS304, carbon steel
I/O	8 output(5V), 8 input(24V)
Communication	RS485, Modbus TCP/IP
Pneumatic	0.4~0.6MPa
Power	Single Phase AC-220V ±10%, 50/60HZ
Working environment	0~40°C, 90%R.H condensation is not allowed

* Normally, the diameter of the testing material 1-5mm.

Structure & Dimension

Unit: mm

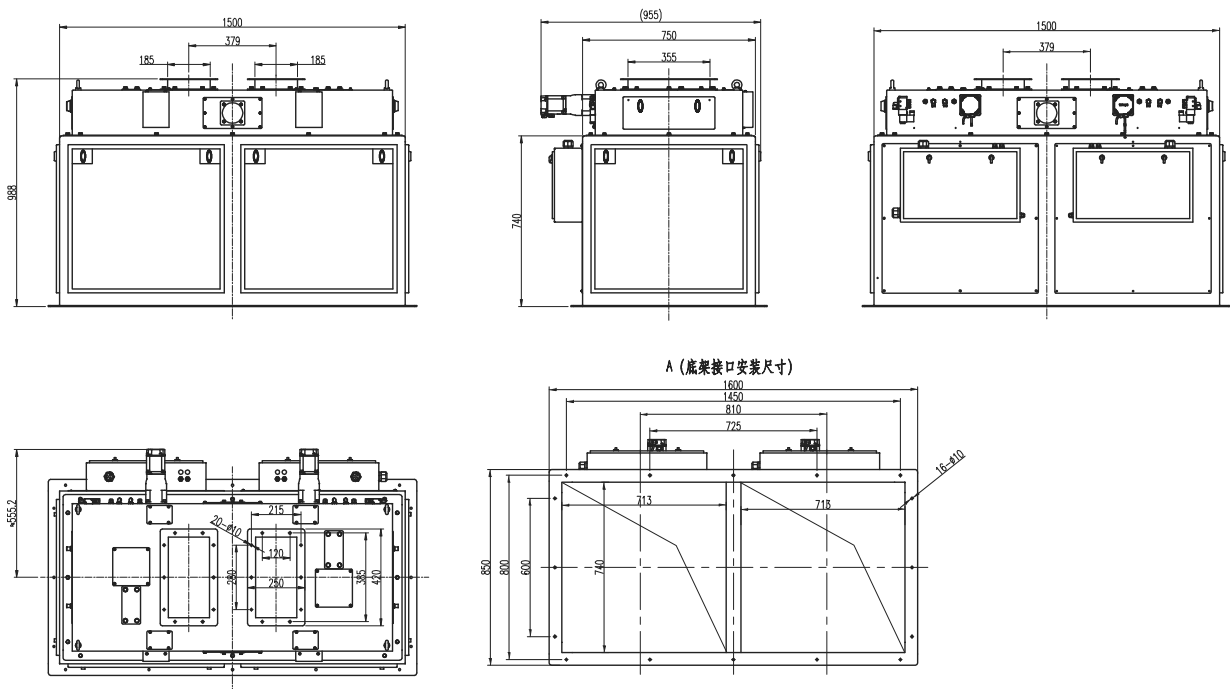

BARRANQUILLA

Cll. 45 No. 39 - 07 PBX.: (605) 370 3366

Cra. 40 No. 37 - 55 Tel.: (605) 379 23 13

MEDELLIN

Carrera 43G No. 26 - 75 Tel: (604) 401 77 07

CALI

Carrera 10 No. 9 - 08 Tel: (602) 895 96 23

www.macoser.co



info@macoser.com.co



@macoser.co



MACOSER®