

# DYNAMIC CHECKWEIGHER CW-600G

- This checkweigher is suitable for standard applications in food and other industries;
- System can store 100 product options for a wide variety of open or closed products in food and industrial production environments;
- System can be intergrated with metal detector.

## Multiple industrial application



Food



Chemical



Accessaries



**10-600g**

Weighing range



**±0.5g**

Accuracy



**200+** Pcs/min

Speed



## Standard specification

Model	CW-600G
Weighing range	10~600g
Scale division	± 0.1g
Highest Accuracy(3σ) *	0.5g
Highest Weighing speed *	200 pcs/min
Belt speed	5~60 m/min
Belt size	310×250mm
Weighing platform Height **	750±50mm
Tested object size	Length: 50~240mm Width: 20~150mm Height: 10~180mm
Belt material	PVC (white)
Structure of the material	Carbon steel, SS304 stainless steel (weighing platform)
Alarm light	3-color signal light (Red, yellow, green) , Optional buzzer
Display size	10-inch color touch screen
Rejector lineup	Options: swing type, push type or lift up type rejector
Power	Single Phase AC-220V ±10%, 50/60HZ
operating temperature	0~40°C
IP grade	IP54 ,IP65 Optional

\* Depend on the weight, size, and material of test object. Test accuracy: 0.5g at 200pcs/min

## Dimensions

Unit:mm

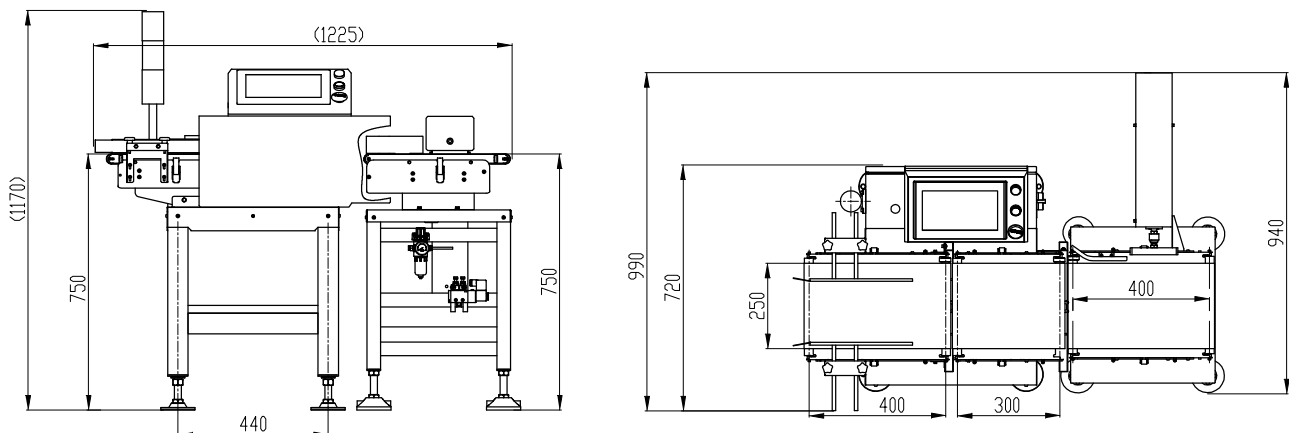

## **BARRANQUILLA**

Cll. 45 No. 39 - 07 PBX.: (605) 370 3366

Cra. 40 No. 37 - 55 Tel.: (605) 379 23 13

## **MEDELLIN**

Carrera 43G No. 26 - 75 Tel: (604) 401 77 07

## **CALI**

Carrera 10 No. 9 - 08 Tel: (602) 895 96 23

[www.macoser.co](http://www.macoser.co)



info@macoser.com.co



@macoser.co



**MACOSER<sup>®</sup>**